



P24C256F

I²C-Compatible Serial E²PROM

Datasheet V1.4

General Description

The P24C256F is I²C-compatible Serial EEPROM (Electrically Erasable Programmable Memory) device. It contains a memory array of 256 Kbits (32 Kbytes), which is organized in 64 bytes per page.

Features

- Single Supply Voltage and High Speed Mode
 - ◇ Minimum operating voltage down to 1.65 V
 - ◇ 400 kHz/1 MHz/3.4 MHz clock from 1.65 V to 3.6 V
- Low power CMOS technology
 - ◇ Read current 0.15 mA (400 kHz, typical)
- Schmitt Trigger, Filtered Inputs for Noise Suppression
- Transparent ECC on each group of four bytes which can correct 1 bit error
- Additional write lockable page (Identification page)
- Additional 128 bits Serial Number (Unique ID)
- Additional Write Lockable Page
- 64 bytes Page Write Modes, Partial Page Writes Allowed
- Write protect of the whole memory array
- Self-timed Write Cycle (5 ms maximum)
- High Reliability
 - ◇ Endurance: 1 Million Write Cycles
 - ◇ Data Retention: 100 Years
 - ◇ HBM: 4 kV
 - ◇ Latch up Capability: +/- 200 mA(25 C)
- Package:
 - ◇ PDIP8, SOP8(150mil), MSOP8, TSSOP8 and DFN8/UDFN8

1. Pin Configuration

1.1 Pin Configuration

Figure 1-1 Pin Configuration

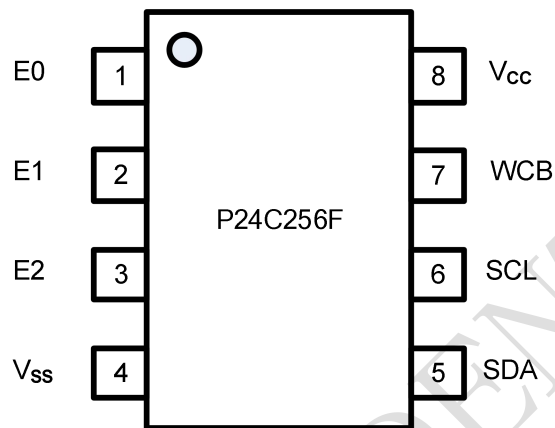

PDIP8/TSSOP8/SOP8(150mil)/DFN8/UDFN8/MSOP8

1.2 Pin Definition

Table 1-1 Pin Definition

Pin	Name	Type	Description
1	E0	Input	Slave Address Setting
2	E1	Input	Slave Address Setting
3	E2	Input	Slave Address Setting
4	Vss	Ground	Ground
5	SDA	I/O	Serial Data Input and Serial Data Output
6	SCL	Input	Serial Clock Input
7	WCB	Input	Write Control, Low Enable Write
8	Vcc	Power	Power

1.3 Pin Descriptions

Serial Clock (SCL): The SCL input is used to positive-edge clock data in and negative-edge clock data out of each device.

Serial Data (SDA): The SDA pin is bidirectional for serial data transfer. This pin is open drain driven and may be wire-OR'ed with any number of other open-drain or open-collector devices.

Device Addresses (E2, E1, E0): The E2, E1, and E0 pins are device address inputs. Typically, the E2, E1, and E0 pins are for hardware addressing and a total of 8 devices can be connected on a single bus system. If these pins are left floating, the E2, E1, and E0 pins will be internally pulled down to Vss.

Write Control (WCB): The Write Control input, when WCB is connected directly to Vcc, all write operations to the memory are inhibited. When connected to Vss, allows normal write operations. If the pin is left floating, the WCB pin will be internally pulled down to Vss.

Supply Voltage(Vcc): Vcc is the supply voltage.

Ground(Vss): Vss is the reference for the Vcc supply voltage.

PUYA CONFIDENTIAL

2. Block Diagram

Figure 2-1 Block Diagram

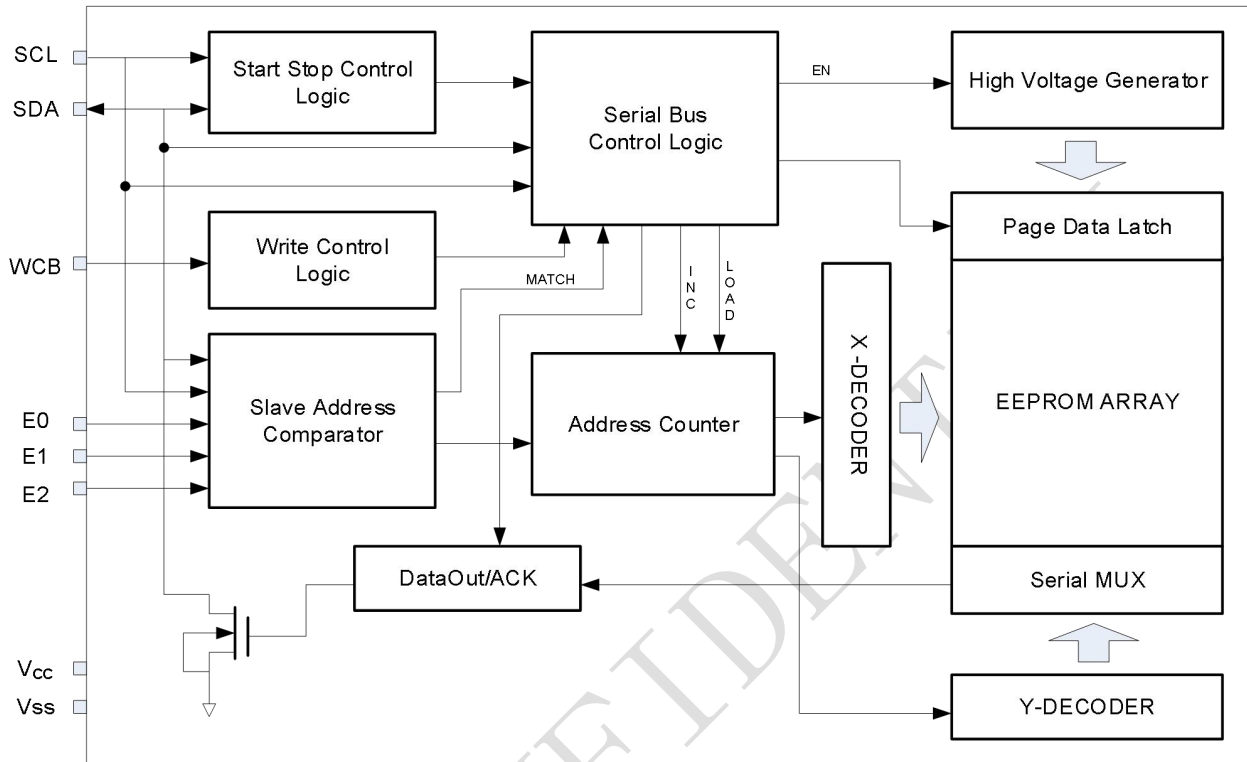

PUYA CONFIDENTIAL

3. Electrical Characteristics

Table 3-1 Absolute Maximum Ratings ^[1]

Symbol	Parameter	Min.	Max.	Units
T _{STG}	Storage Temperature	-65	150	°C
T _A	Ambient operating temperature	-40	85	°C
V _{CC}	Supply Voltage	-0.5	4.0	V
V _{IO}	Input or output range	-0.5	4.0	V
I _{OL}	DC output current (SDA=0)	-	5	mA

Note: [1] Stresses above those listed under “Absolute Maximum Ratings” may cause permanent damage to the device. This is a stress rating only and functional operation of the device at those or any other conditions above those indicated in the operational listings of this specification is not implied. Exposure to maximum rating conditions for extended periods may affect device reliability.

Table 3-2 Pin Capacitance ^[1]

Symbol	Parameter	Max.	Units	Test Condition
C _{I/O}	Input/output Capacitance (SDA)	8	pF	V _{I/O} =V _{SS}
C _{IN}	Input Capacitance (SCL)	6	pF	V _{IN} =V _{SS}

Note: [1] Test Conditions: T_A= 25°C, f_{SCL} = 1MHz, V_{CC} =3.6V.

Table 3-3 DC Characteristics (Unless otherwise specified, V_{CC} = 1.65 V to 3.6V, T_A= -40°C to +85°C)

Symbol	Parameter	Min.	Typ.	Max.	Unit	Test Condition
V _{CC}	Supply Voltage	1.65	-	3.6	V	
I _{sb}	Standby Current (Standby mode)	-	0.1	3.0	uA	V _{CC} = 1.8V, V _{in} = V _{SS} or V _{CC} Device is not selected
I _{CC1}	Supply Current (Read)	-	0.15	0.5	mA	V _{CC} = 1.8V, f _{SCL} = 400KHz
		-	-	0.5	mA	V _{CC} = 3.6V, f _{SCL} = 400KHz
		-	-	1.0	mA	V _{CC} = 3.6V, f _{SCL} = 1MHz
		-	-	3.0	mA	V _{CC} = 3.6V, f _{SCL} = 3.4MHz
I _{CC2}	Supply Current (Write)	-	1.0	2.0	mA	During t _w , 1.65V < V _{CC} < 3.6V
I _{LI}	Input Leakage Current	-2	-	+2	μA	V _{IN} = V _{CC} or V _{SS} , device in standby mode
I _{LO}	Output Leakage Current	-2	-	+2	μA	SDA in Hi-Z, external voltage applied on SDA: V _{SS} or V _{CC}
V _{IL}	Input Low Voltage	-0.45	-	0.3 V _{CC}	V	SCL, SDA
V _{IH}	Input High Voltage	0.7V _{CC}	-	V _{CC} +0.5	V	SCL, SDA
V _{OL}	Output Low Voltage	-	-	0.4	V	I _{OL} = 2.1mA, V _{CC} = 2.5V

Table 3-4 Fast Mode AC Characteristics (Unless otherwise specified, $V_{CC} = 1.65V$ to $3.6V$, $T_A = -40\text{ }^\circ\text{C}$ to $+85\text{ }^\circ\text{C}$, $C_L = 100pF$. Test Conditions are listed in Notes [2])

Symbol	Parameter	1.65≤V _{CC} ≤3.6			1.65≤V _{CC} ≤3.6			Units
		Min.	Typ.	Max.	Min.	Typ.	Max.	
f _{SCL}	Clock Frequency	-	-	400	-	-	1000	kHz
t _{LOW}	Clock Pulse Width Low	1.3	-	-	0.55	-	-	μs
t _{HIGH}	Clock Pulse Width High	0.6	-	-	0.3	-	-	μs
t _{AA}	Clock Low to Data Out Valid	0.05	-	0.9	0.05	-	0.50	μs
t _I	Noise Suppression Time	-	-	0.05	-	-	0.05	μs
t _{BUF}	Time the bus must be free before a new transmission can start	1.3	-	-	0.5	-	-	μs
t _{HD.STA}	Start Hold Time	0.6	-	-	0.25	-	-	μs
t _{SU.STA}	Start Setup Time	0.6	-	-	0.25	-	-	μs
t _{HD.DAT}	Data in Hold Time	0	-	-	0	-	-	μs
t _{SU.DAT}	Data in Setup Time	0.1	-	-	0.08	-	-	μs
t _R	Inputs Rise Time ^[1]	-	-	0.3	-	-	0.3	μs
t _F	Inputs Fall Time ^[1]	-	-	0.3	-	-	0.12	μs
t _{SU.STO}	Stop Setup Time	0.6	-	-	0.25	-	-	μs
t _{DH}	Data Out Hold Time	0.05	-	-	0.05	-	-	μs
t _{SU.WCB}	WCB pin Setup Time	1	-	-	0.6	-	-	μs
t _{HD.WCB}	WCB pin Hold Time	1	-	-	0.6	-	-	μs
t _{WR}	Write Cycle Time	-	-	5	-	-	5	ms

Notes: [1] This parameter is ensured by characterization not 100% tested

[2] AC measurement conditions:

- ✧ t_{AA} is the time (from the falling edge of SCL) required by the SDA bus line to reach either 0.3V_{CC} or 0.7V_{CC}, assuming that R_{bus} × C_{bus} time constant is within 400ns for 0.4MHz frequency, within 120ns for 1 MHz frequency
- ✧ R_L (connect to VCC): 1.3kΩ
- ✧ C_L = 100pF
- ✧ Input pulse voltage: 0.2V_{CC} to 0.8V_{CC}
- ✧ Input rise and fall time: < 50ns
- ✧ Input and output timing reference voltage: 0.3V_{CC} and 0.7V_{CC}

Table 3-5 High Speed Mode AC Characteristics (Unless otherwise specified, $V_{CC} = 1.65V$ to $3.6V$, $T_A = -40^\circ C$ to $+85^\circ C$, $C_L = 100pF$. Test Conditions are listed in Notes [2])

Symbol	Parameter	1.65 ≤ V _{CC} ≤ 3.6			Units
		Min.	Typ.	Max.	
f _{SCL}	Clock Frequency	-	-	3400	kHz
t _{LOW}	Clock Pulse Width Low	0.16	-	-	μs
t _{HIGH}	Clock Pulse Width High	0.06	-	-	μs
t _{AA}	Clock Low to Data Out Valid	0.01	-	0.14	μs
t _i	Noise Suppression Time	-	-	0.01	μs
t _{BUF}	Time the bus must be free before a new transmission can start	0.3	-	-	μs
t _{HD.STA}	Start Hold Time	0.16	-	-	μs
t _{SU.STA}	Start Setup Time	0.16	-	-	μs
t _{HD.DAT}	Data in Hold Time	0	-	-	μs
t _{SU.DAT}	Data in Setup Time	0.01	-	-	μs
t _R	Inputs Rise Time ^[1]	0.01	-	0.08	μs
t _F	Inputs Fall Time ^[1]	0.01	-	0.08	μs
t _{SU.STO}	Stop Setup Time	0.16	-	-	μs
t _{DH}	Data Out Hold Time	0.05	-	-	μs
t _{SU.WCB}	WCB pin Setup Time	0.6	-	-	μs
t _{HD.WCB}	WCB pin Hold Time	0.6	-	-	us
t _{WR}	Write Cycle Time	-	-	5	ms

Notes: [3] AC measurement conditions:

- ◇ t_{AA} is the time (from the falling edge of SCL) required by the SDA bus line to reach either 0.3V_{CC} or 0.7V_{CC}, assuming that R_{bus} × C_{bus} time constant is within 20ns
- ◇ R_L (connect to V_{CC}): 1.3kΩ
- ◇ C_L = 15pF
- ◇ Input pulse voltage: 0.2V_{CC} to 0.8V_{CC}
- ◇ Input rise and fall time: < 50ns
- ◇ Input and output timing reference voltage: 0.3V_{CC} or 0.7V_{CC}

Table 3-6 Reliability Characteristic ^[1]

Symbol	Parameter	Min.	Typ.	Max.	Unit
EDR ^[2]	Endurance	1,000,000			Write cycles
DRET ^[3]	Data retention	100			Years

Note: [1] This parameter is ensured by characterization and is not 100% tested

[2] Under the condition: 25°C, 3.3V, Page mode

[3] Test condition: T_A = 55°C

Figure 3-1 Bus Timing

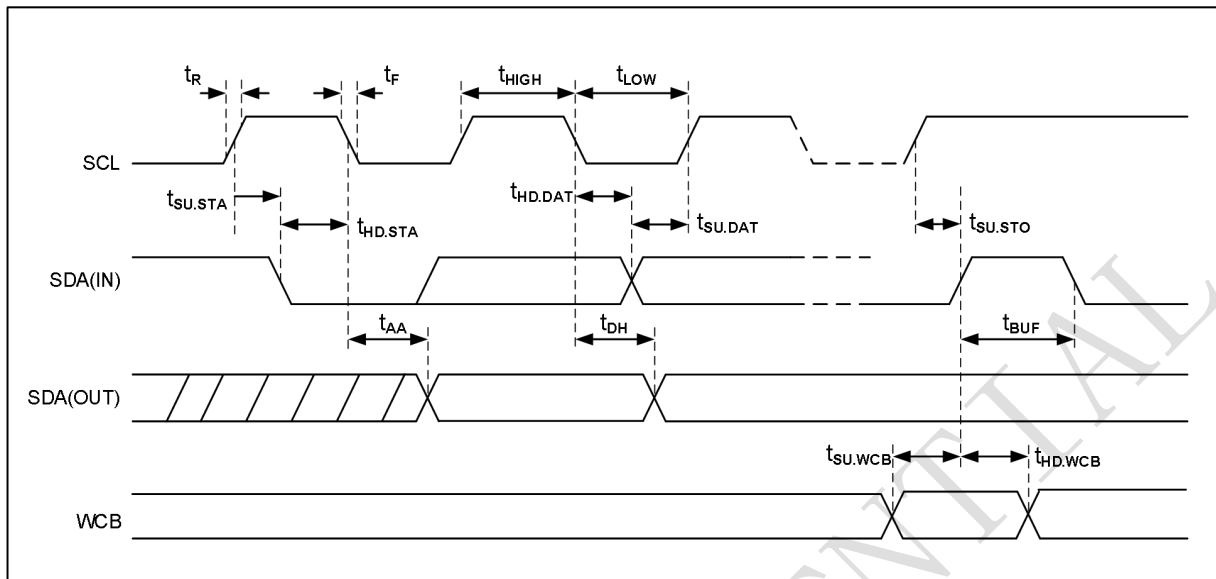
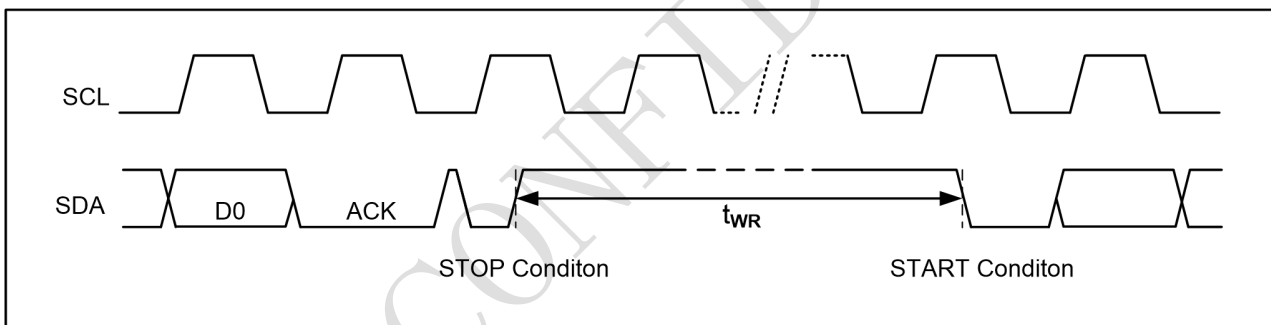

Figure 3-2 Write Cycle Timing



Note: [1] The write cycle time t_{WR} is the time from a valid stop condition of a write sequence to the end of the internal write cycle.

Device Power-Up

The EEPROM has a built-in power-on-reset circuit that initializes itself at the same time during power-on. Unsuccessful initialization may cause a malfunction. To operate the power-on-reset circuit normally, the following conditions must be satisfied to raise the power supply voltage.

When initialization is successfully completed by the power-on-reset circuit, the EEPROM enters the standby status. t_{VSL} is the time required to initialize the EEPROM. No instructions are accepted during this time.

Figure 3-3 Power up Timing

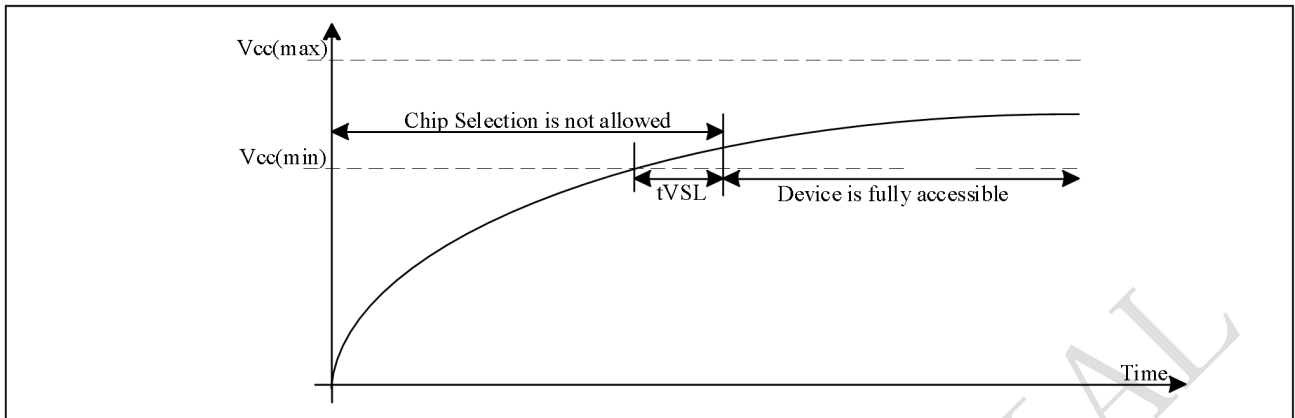

Power Up/Down and Voltage Drop

For Power-down to Power-up operation, the VCC of EEPROM device must below VPWD for at least tPWD timing. Please check the table below for more detail.

Figure 3-4 Power down-up Timing

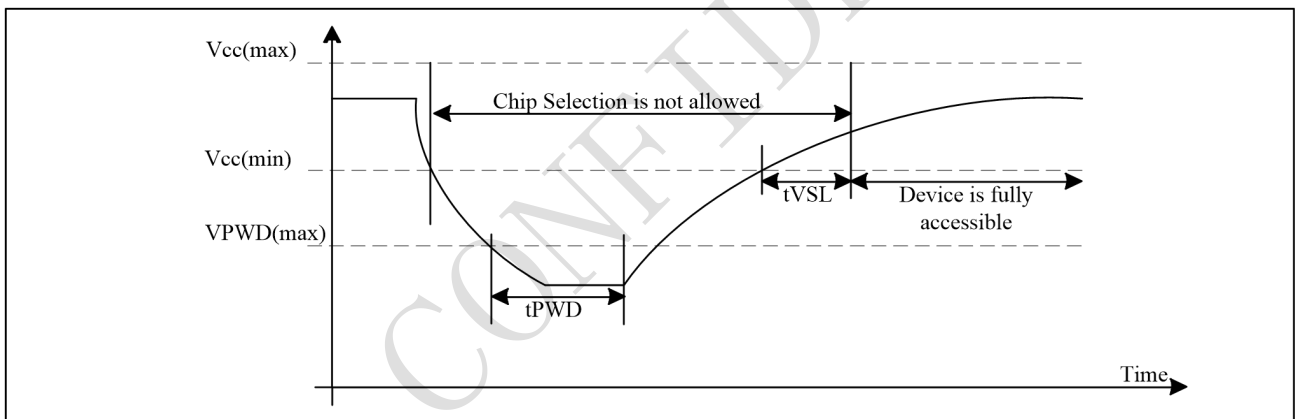

Symbol	Parameter	min	max	unit
VPWD	VCC voltage needed to below VPWD for ensuring initialization will occur		0.7	V
tPWD	The minimum duration for ensuring initialization will occur	300		us
tVSL	VCC(min.) to device operation	100		us
tVR	VCC Rise Time	1	500000	us/V

4. Device Operation

4.1 Data Input

The SDA pin is normally pulled high with an external device. Data on the SDA pin may change only during SCL low time periods (see to Figure 4-1). Data changes during SCL high periods will indicate a start or stop condition as defined in Figure 4-2.

Figure 4-1 Data Validity

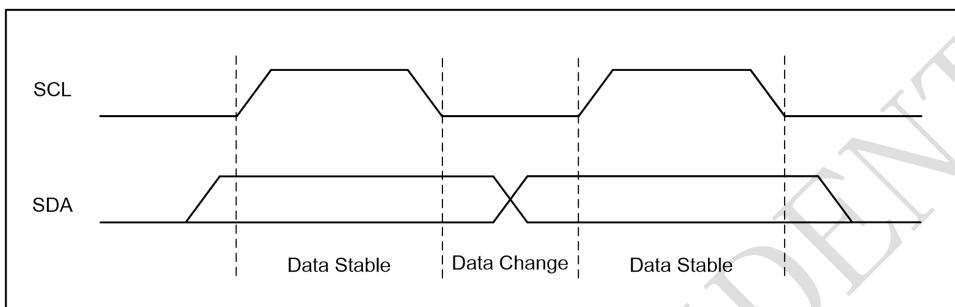

4.2 Start Condition

A high-to-low transition of SDA with SCL high is a start condition which must precede any other command (see to Figure 4-2).

4.3 Stop Condition

A low-to-high transition of SDA with SCL high is a stop condition. After a read sequence, the stop command will place the P24C256F in a standby mode (see Figure 4-2).

Figure 4-2 Start and Stop Definition

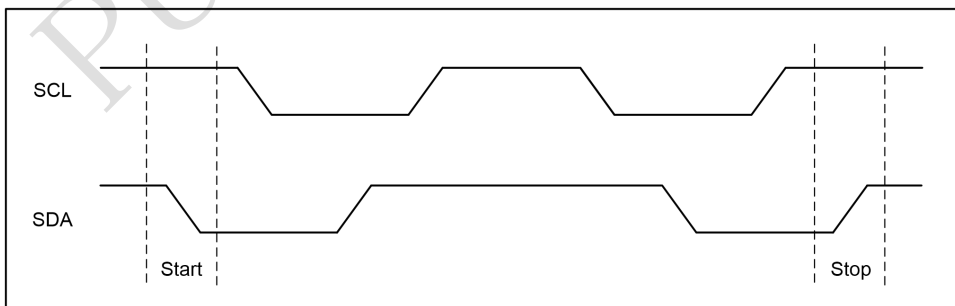

4.4 Acknowledge (ACK)

All addresses and data words are serially transmitted to and from the P24C256F in 8-bit words. The P24C256F sends a “0” to acknowledge that it has received each word. This happens during the ninth clock cycle.

Figure 4-3 Output Acknowledge

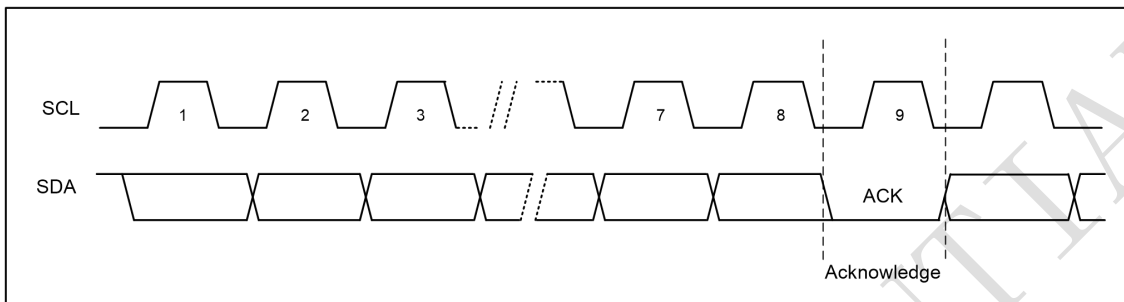

4.5 Power Up Sequence

During a power-up sequence, the V_{CC} supplied to P24C256F should monotonically rise from V_{SS} to the minimum V_{CC} level with a slew rate no greater than 1V/us.

To prevent inadvertent write operations or other spurious events from happening during a power-up sequence, the P24C256F includes a power-on-reset circuit. Upon power-up, the device will not respond to any commands until the V_{CC} level crosses the internal voltage threshold and waiting 100 μ s that brings the device out of reset and into standby mode.

4.6 Standby Mode

The P24C256F features a low-power standby mode which is enabled: (a) after a fresh power up, (b) after receiving a STOP bit in read mode, and (c) after completing a self-time internal programming operation

4.7 Soft Reset

After an interruption in protocol, power loss or system reset, any two-wire part can be reset by following these steps: (a) Create a start condition, (b) Clock nine cycles, and (c) create another start bit followed by stop bit condition, as shown below. The device is ready for the next communication after the above steps have been completed.

Figure 4-4 Soft Reset

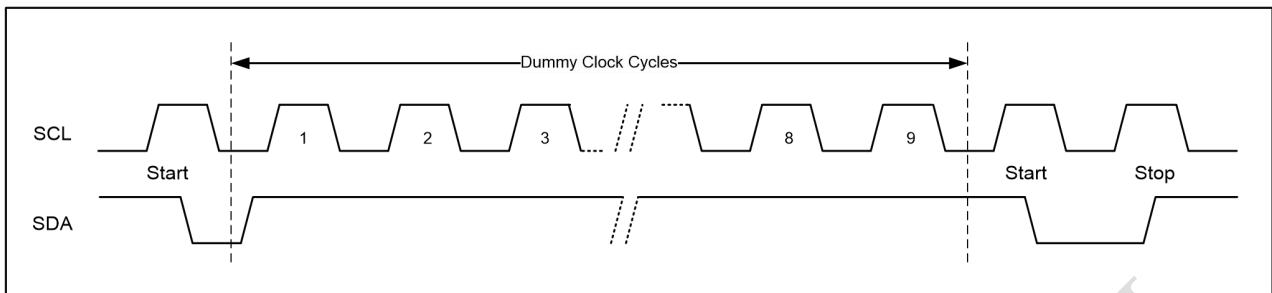

4.8 Device Addressing

The P24C256F requires an 8-bit device address word following a start condition to enable the chip for a read or write operation (see Figure 4-5). The device address word consists of a mandatory one-zero sequence for the first four most-significant bits, as shown.

Figure 4-5 Device Address

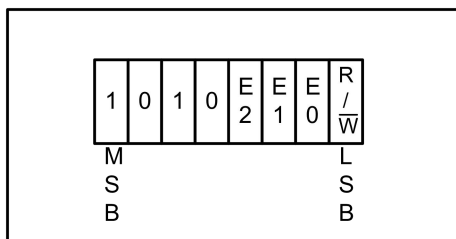

The three E2, E1, and E0 device address bits allow as many as eight devices on the same bus. These bits must compare to their corresponding hardwired input pins.

The E2, E1, and E0 pins use an internal proprietary circuit that biases them to a logic low condition if the pins are floating.

The eighth bit of the device address is the read/write operation select bit. A read operation is initiated if this bit is high and a write operation is initiated if this bit is low. Upon a compare of the device address, the Chip will output a zero. If a compare is not made, the device will return to a standby state.

Table 4-1 Device Address

Chip	Access area	Bit 7	Bit 6	Bit 5	Bit 4	Bit 3	Bit 2	Bit 1	Bit 0
P24C256F	Normal Area	1	0	1	0	E2	E1	E0	R/W
	ID Page	1	0	1	1	E2	E1	E0	R/W
	Lock Bit	1	0	1	1	E2	E1	E0	R/W
	Serial Number	1	0	1	1	E2	E1	E0	1

Table 4-2 Word Address0

Chip	Data	Bit 7	Bit 6	Bit 5	Bit 4	Bit 3	Bit 2	Bit 1	Bit 0
P24C256F	Normal Area	X	A14	A13	A12	A11	A10	A9	A8
	ID Page	X	X	X	X	0	0	X	X
	Lock Bit	X	X	X	X	X	1	X	X
	Serial Number	X	X	X	X	1	0	X	X

Table 4-3 Word Address1

Chip	Data	Bit 7	Bit 6	Bit 5	Bit 4	Bit 3	Bit 2	Bit 1	Bit 0
P24C256F	Normal Area	A7	A6	A5	A4	A3	A2	A1	A0
	ID Page	X	X	A5	A4	A3	A2	A1	A0
	Lock Bit	X	X	X	X	X	X	X	X
	Serial Number	X	X	X	X	A3	A2	A1	A0

4.9 Data Security

P24C256F has a hardware data protection scheme that allows the user to write protect the whole memory when the WCB pin is Vcc.

4.10 ECC (Error Correction Code) and Write cycling

The Error Correction Code (ECC) is an internal logic function which is transparent for the I2C communication protocol.

The ECC logic is implemented on each group of four EEPROM bytesgroup^[1]. Inside a group, if a single bit out of the four bytes happens to be erroneous during a Read operation, the ECC detects this bit and replaces it with the correct value. The read reliability is therefore much improved.

Even if the ECC function is performed on groups of four bytes, a single byte can be written/cycled independently. In this case, the ECC function also writes/cycles the three other bytes located in the same group^[1]. As a consequence, the maximum cycling budget is defined at group level and the cycling can be distributed over the 4 bytes of the group: the sum of the cycles seen by byte0, byte1, byte2 and byte3 of the same group must remain below the maximum value.

Note: [1] A group of four bytes is located at addresses $[4*N, 4*N+1, 4*N+2, 4*N+3]$, where N is an integer

4.11 High Speed Mode (HS-mode)

The P24C256F supports 3.4MHz high speed mode. A master code (00001XXXb) must be issued to place the device into high speed mode. Communication between master and slave will then be enabled for speeds up to 3.4MHz. A STOP condition will exit HS-mode. Single-byte and multiple-byte read and write are supported.

Figure 4-6 High Speed Mode Communication

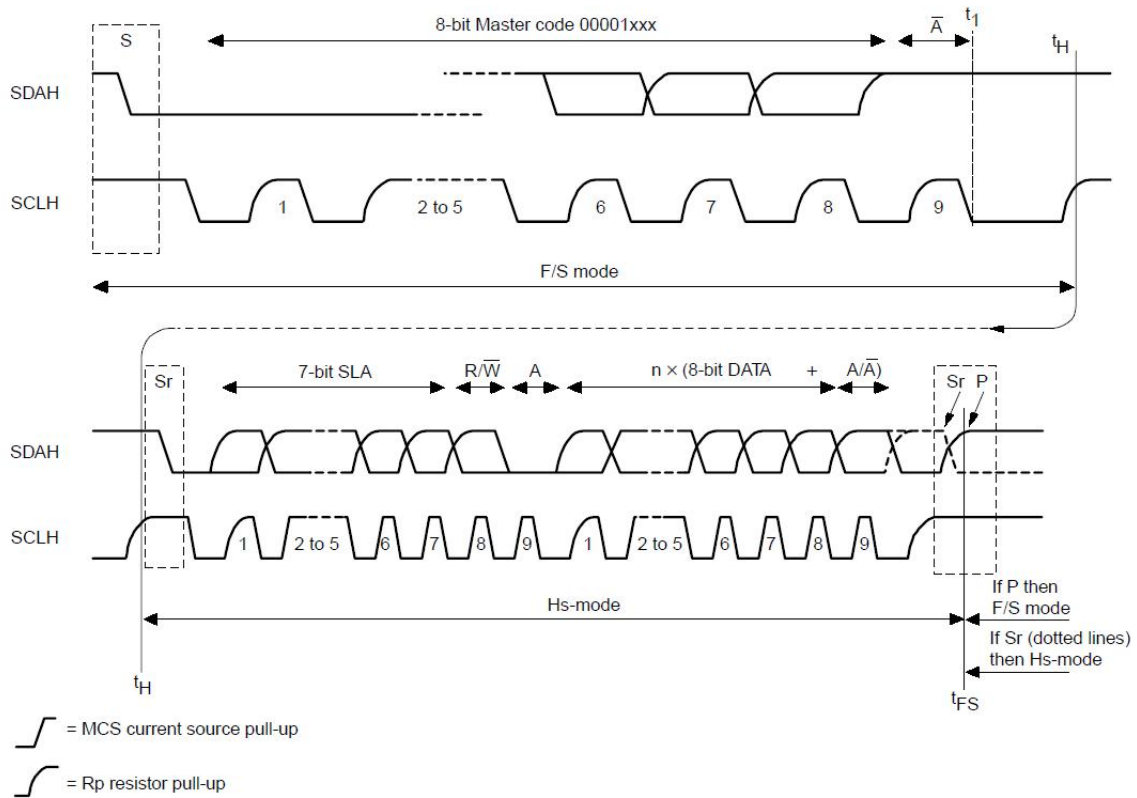

Sr: Repeated Start Flag

PUYA

5. Instructions

5.1 Write Operations

5.1.1 Byte Write

A write operation requires two 8-bit data word address (A14~A0) following the device address word **and** acknowledgment. Upon receipt of this address, the P24C256F will again respond with a “0” and then clock in the first 8-bit data word. Following receipt of the 8-bit data word, the P24C256F will output a “0” and the addressing device, such as a microcontroller, must terminate the write sequence with a stop condition. And then the P24C256F enters an internally timed write cycle, all inputs are disabled during this write cycle and the P24C256F will not respond until the write is complete (see Figure 5-1).

Figure 5-1 Byte Write

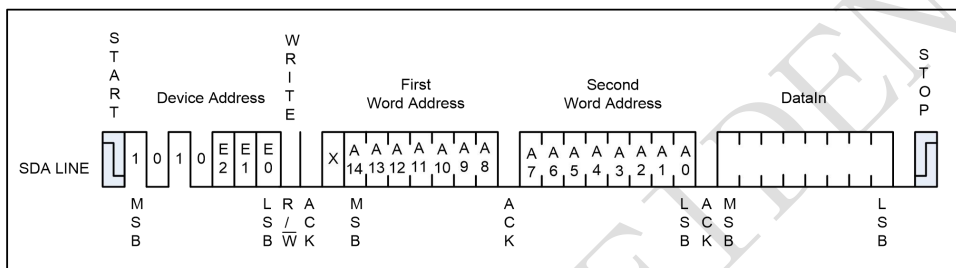

5.1.2 Page Write

A page write is initiated the same as a byte write, but the master does not send a stop condition after the first data word is clocked in. Instead, after the P24C256F acknowledges receipt of the first data word, the master can transmit more data words. The P24C256F will respond with a “0” after each data word received. The microcontroller must terminate the page write sequence with a stop condition.

Figure 5-2 Page Write

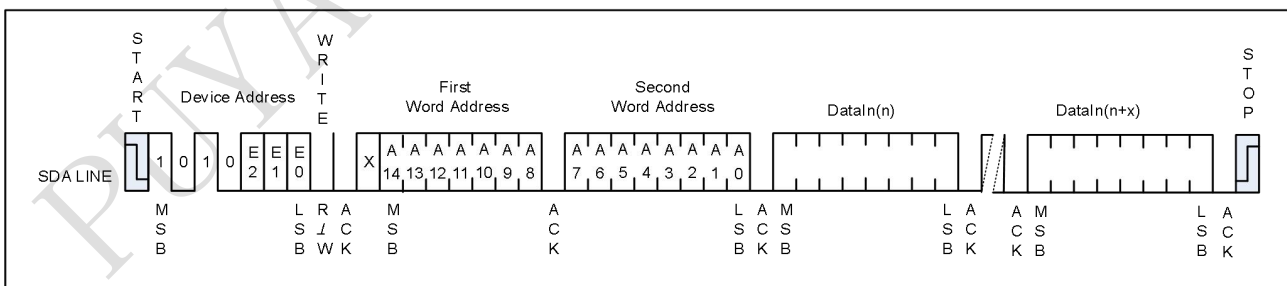

The lower six bits of the data word address are internally incremented following the receipt of each data word. The higher data word address bits are not incremented, retaining the memory page row location. When the word address, internally generated, reaches the page boundary, the following byte is placed at the beginning of the same page. If more than 64 data words are transmitted to the P24C256F, the data word address will roll-over, and previous data will be overwritten. The address roll-over during write is from the last byte of the current page to the first byte of the same page.

5.1.3 Acknowledge Polling

Once the internally timed write cycle has started and the P24C256F inputs are disabled, acknowledge polling can be initiated. This involves sending a start condition followed by the device address word. The read/write bit is representative of the operation desired. Only if the internal write cycle has completed will the P24C256F respond with a “0”, allowing the read or write sequence to continue.

5.1.4 Write Identification Page

The Identification Page (64 bytes) is an additional page which can be written and later permanently locked in Read-only mode. It is written by the Write Identification Page instruction. This instruction uses the same protocol and format as Page Write, except for the following differences:

- Device type identifier = 1011b
- MSB address A11~A10 must be ‘00’ while other bits in A15~A6 are don’t care.
- LSB address bits A5~A0 define the byte address inside the Identification page.

If the Identification page is locked, the data bytes transferred during the Write Identification Page instruction are not acknowledged (NoACK).

5.1.5 Lock Identification Page

The Lock Identification Page instruction (Lock ID) permanently locks the Identification page in Read-only mode. The Lock ID Page instruction is similar to Byte Write with the following specific conditions:

- Device type identifier = 1011b
- Address bit A10 must be ‘1’; all other address bits are don’t care
- The data byte must be equal to the binary value xxxx xx1x, where x is don’t care

5.2 Read Operations

Read operations are initiated the same way as write operations with the exception that the read/write select bit in the device address word is set to “1”. There are three read operations: Current Address Read; Random Address Read and Sequential Read.

5.2.1 Current Address Read

The internal data word address counter maintains the last address accessed during the last read or write operation, incremented by one. This address stays valid between operations as long as the chip power is maintained. The address roll-over during read is from the last byte of the last memory page to the first byte of the first page.

Once the device address with the read/write select bit set to “1” is clocked in and acknowledged by the P24C256F, the current address data word is serially clocked out. The microcontroller does not respond with an input “0” but does generate a following stop condition (see Figure 5-3).

Figure 5-3 Current Address Read

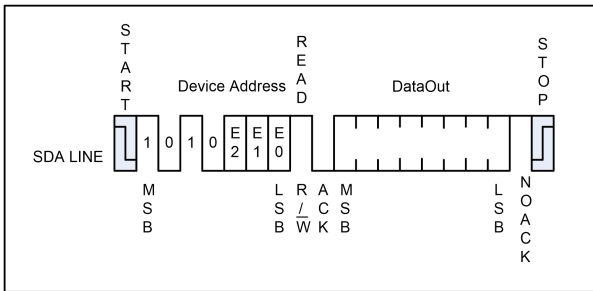

5.2.2 Random Read

A Random Read requires a “dummy” byte write sequence to load in the word address. Once the device address word and word address are clocked in and acknowledged by the P24C256F, the microcontroller must generate another start condition. The microcontroller now initiates a Current Address Read by sending a device address with the read/write select bit high. The P24C256F acknowledges the device address and serially clocks out the data. The microcontroller responds with a “1” and generates stop condition (see Figure 5-4).

Figure 5-4 Random Read

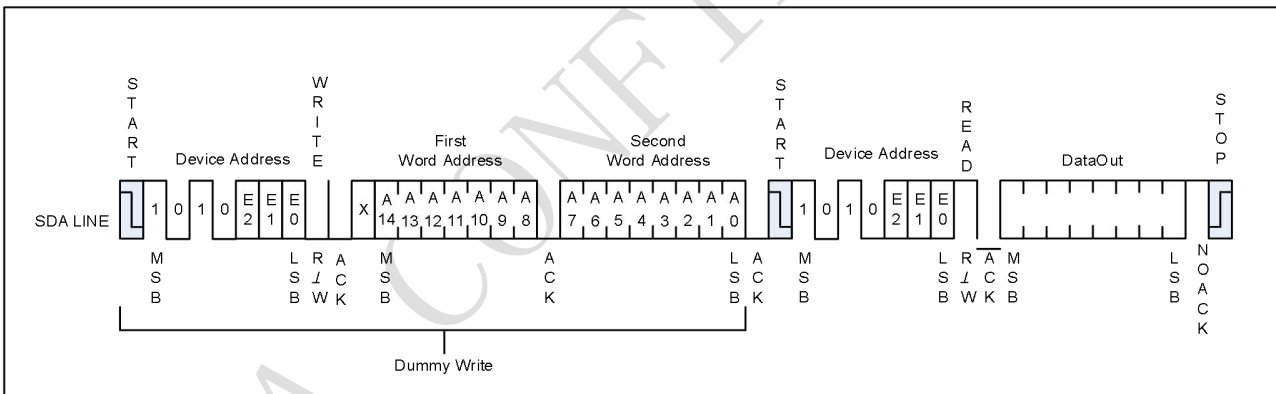

5.2.3 Sequential Read

Sequential Reads are initiated by either a Current Address Read or a Random Address Read. After the microcontroller receives a data byte, it responds with acknowledge. As long as the P24C256F receives acknowledge, it will continue to increment the word address and serially clock out sequential data. When the memory address limit is reached, the word address will roll-over and the Sequential Read will continue. The Sequential Read operation is terminated when the microcontroller responds with a “1” and generates a stop condition (see Figure 5-5).

Figure 5-5 Sequential Read

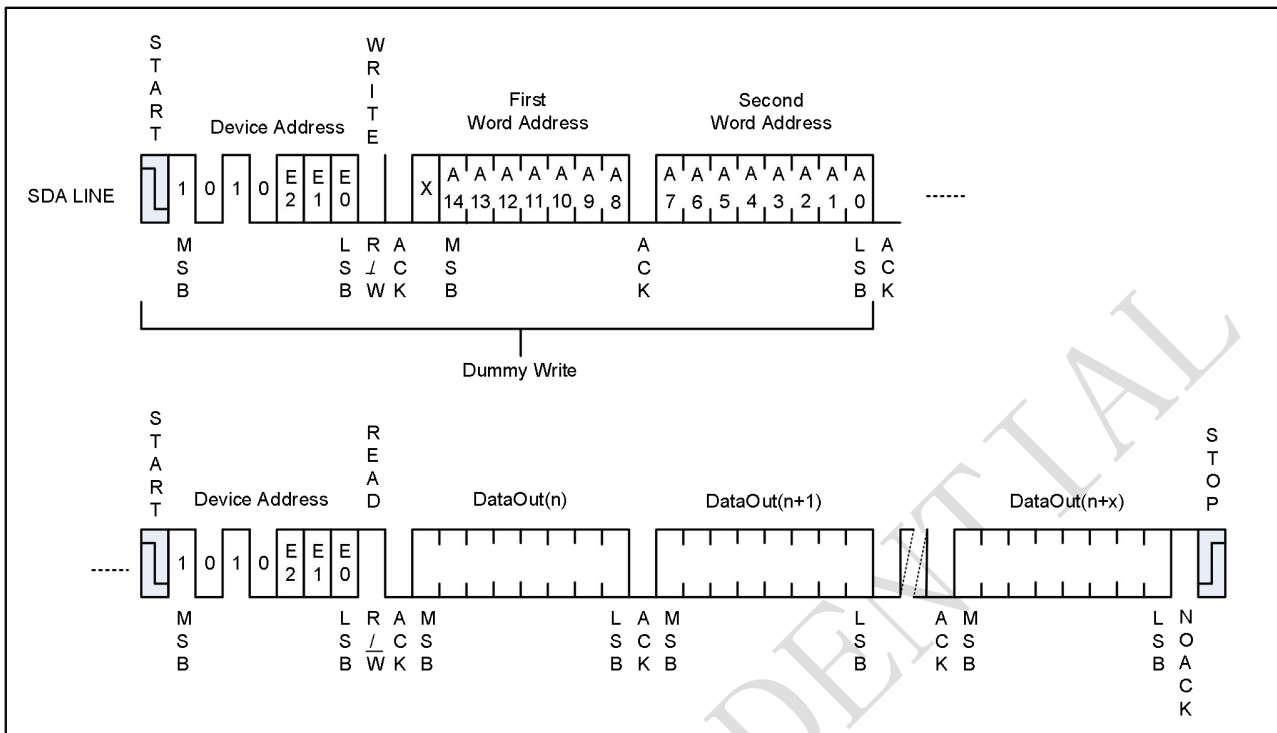

5.2.4 Read Identification Page

The Identification Page (64 bytes) is an additional page which can be written and later permanently locked in Read-only mode. The Identification Page can be read by Read Identification Page instruction which uses the same protocol and format as the Read Command with device type identifier defined as 1011b. The MSB address bits A14~A6 are don't care, the LSB address bits A5~A0 define the byte address inside the Identification Page. The number of bytes to read in the ID page must not exceed the page boundary (e.g. When reading the Identification Page from location 10d, the number of bytes should be less than or equal to 54, as the ID page boundary is 64 bytes).

5.2.5 Read Lock Status

The locked/unlocked status of the Identification page can be checked by transmitting a specific truncated command [Identification Page Write instruction + one data byte] to the device. The device returns an acknowledge bit if the Identification page is unlocked, otherwise a NO-ACK bit if the Identification page is locked.

Figure 5-6 Lock Status Read (When Identification page locked, return NO-ACK after the data-in)

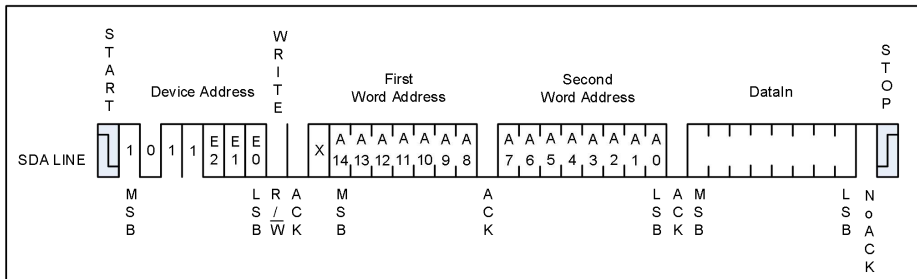

5.2.6 Read Serial Number

The Serial Number is only 16-bytes and is Read-only.

Reading the serial number is similar to the sequential read sequence but requires use of the device address seen in Table 4-1, and the use of a specific word address. The entire 128 bits value must be read from the starting address of the serial number block to guarantee a unique number.

Since the address pointer of the device is shared between the regular EEPROM array and the serial number block, a dummy write sequence, as part of a Random Read or Sequential Read protocol, should be performed to ensure the address pointer is set to zero. Reading the serial number from a location other than the first address of the block will not result in a unique serial number.

Additionally, the word address contains a '10' sequence in bit A11 and A10 of the word address, regardless of the intended address as depicted in Table 4-2. If a word address other than '10' is used, then the device will output unintended data.

When the end of the serial number is reached (16 bytes of data), continued reading of the extended memory region will return 48 bytes data 00, then result in rolling over to the first byte. The Serial Number Read operation is terminated when the microcontroller does not respond with a zero (ACK) and instead issues a Stop condition (see Figure 5-7)

Figure 5-7 Serial Number Read

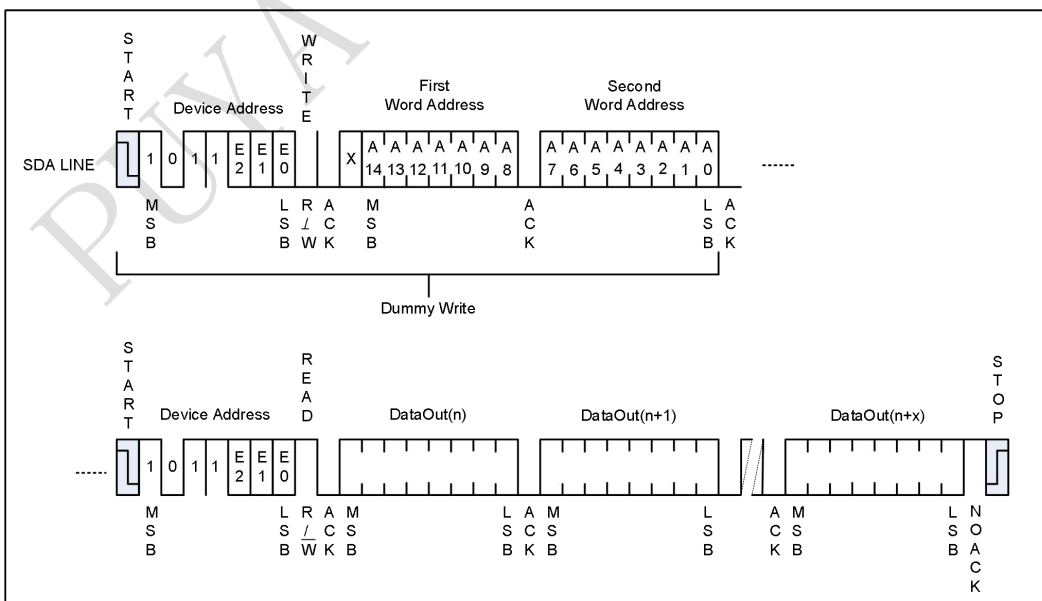

6. Ordering Code Detail

Example:

P 2 4 C 256 F – SS H – M I T

Company Designator

P = Puya Semiconductor

Product Series Name

24C = I2C-compatible Interface EEPROM

Device Density

256 = 256K bits

Device Version

F = Version F

Package Option

DP: PDIP8

SS: SOP8(150mil)

MS: MSOP8

TS: TSSOP8

DN: DFN8

UN: UDFN8

Plating Technology

H: RoHS Compliant, Halogen-free

Operation Voltage

M: 1.65~3.6V

Device Grade

I: -40~85C

Shipping Carrier Option

W: WAFER

T: TUBE

R: TAPE & REEL

7. Package information

7.1 PDIP8

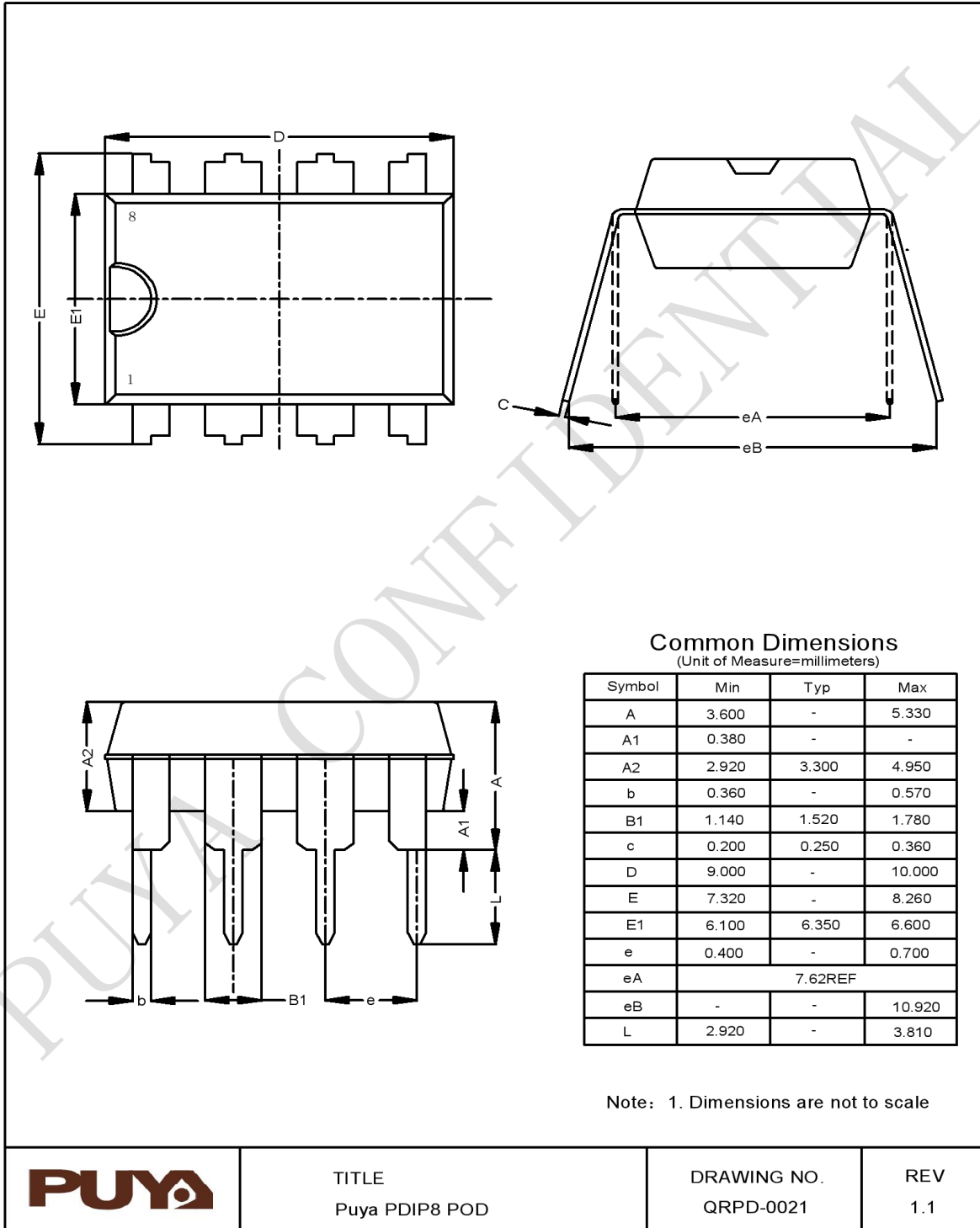

7.2 TSSOP8

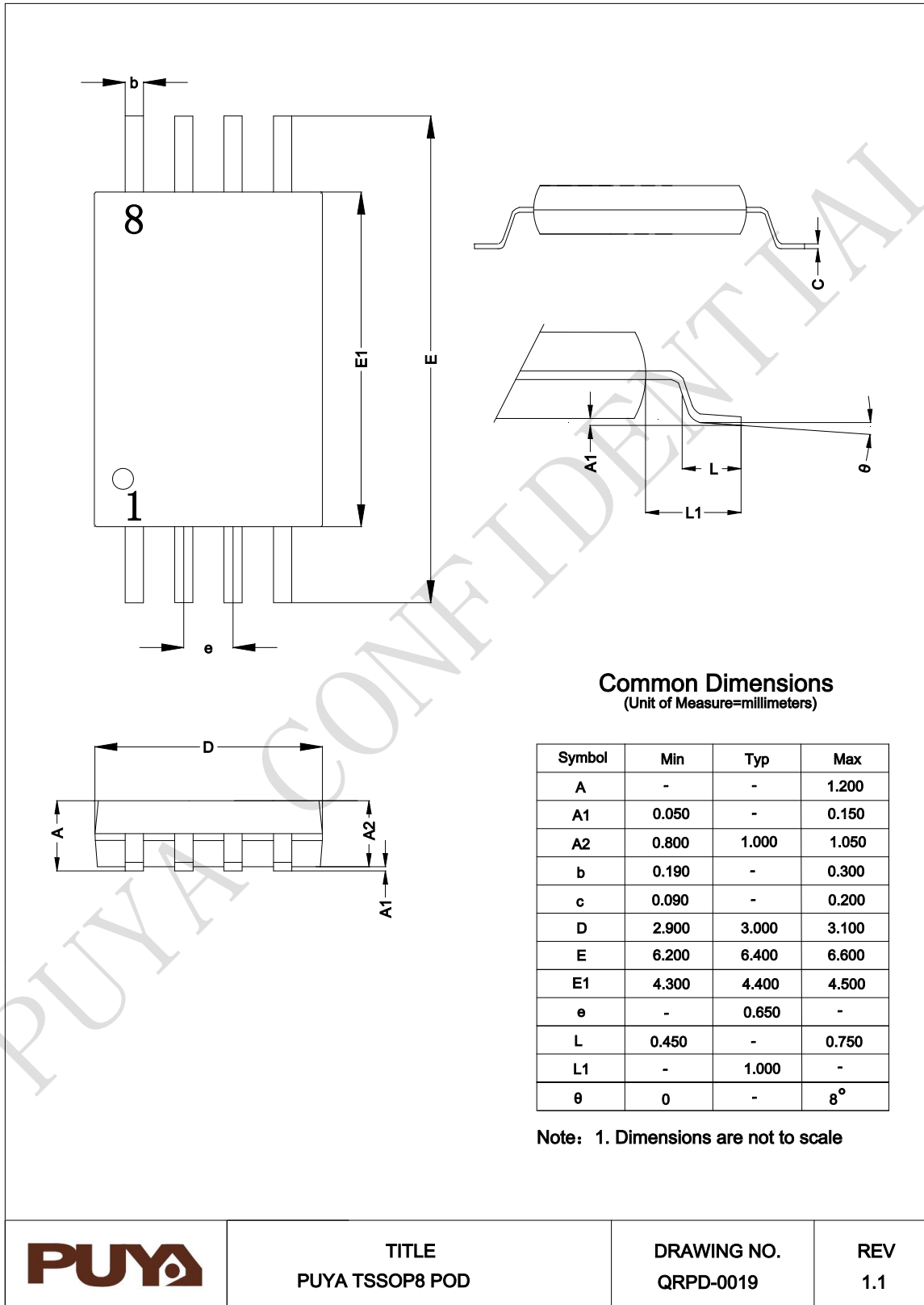

TITLE
PUYA TSSOP8 POD

DRAWING NO.
QRPD-0019

REV
1.1

7.3 SOP8(150mil)

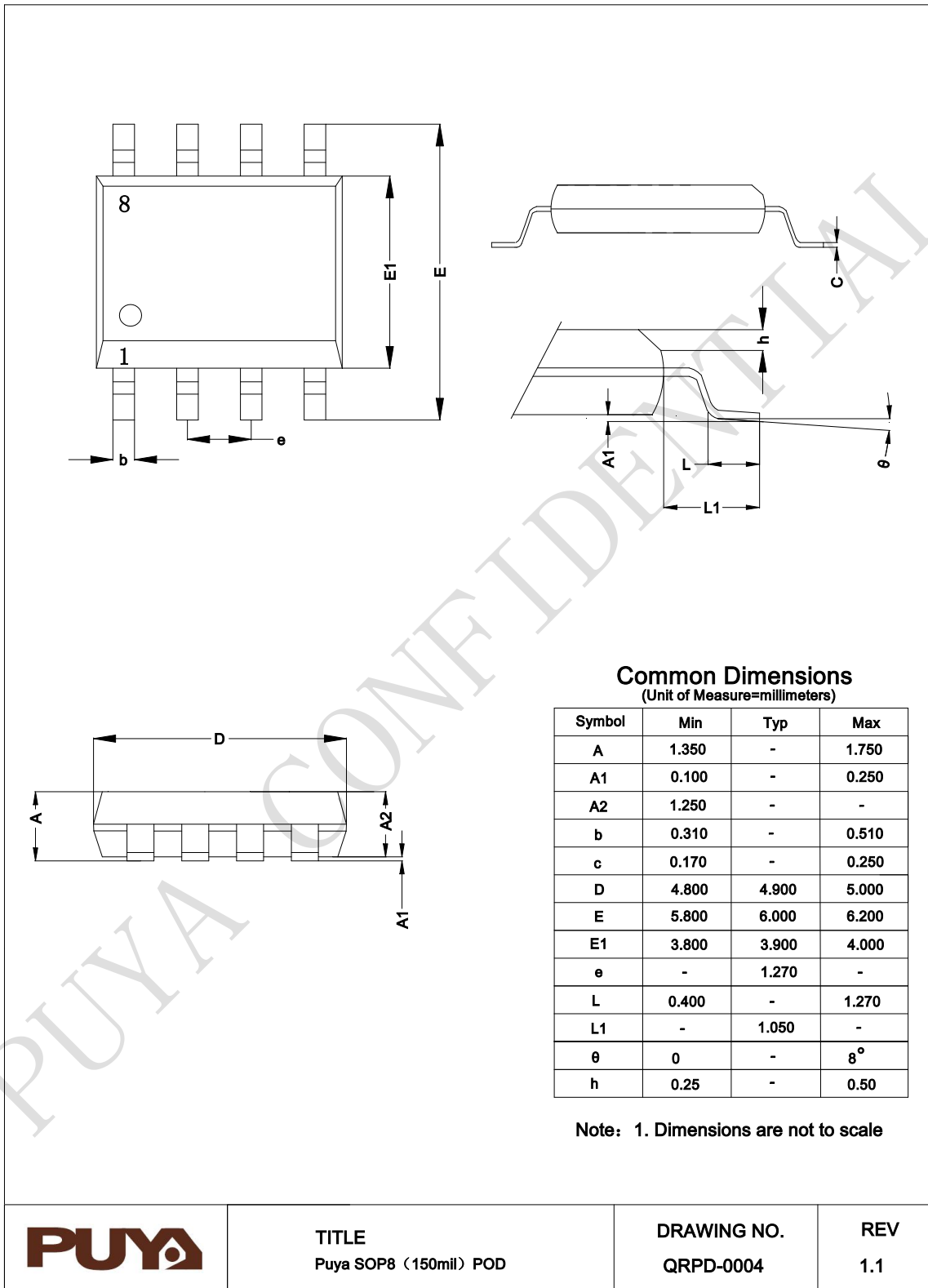

	TITLE	DRAWING NO.	REV
	Puya SOP8 (150mil) POD	QRPD-0004	1.1

7.4 DFN8

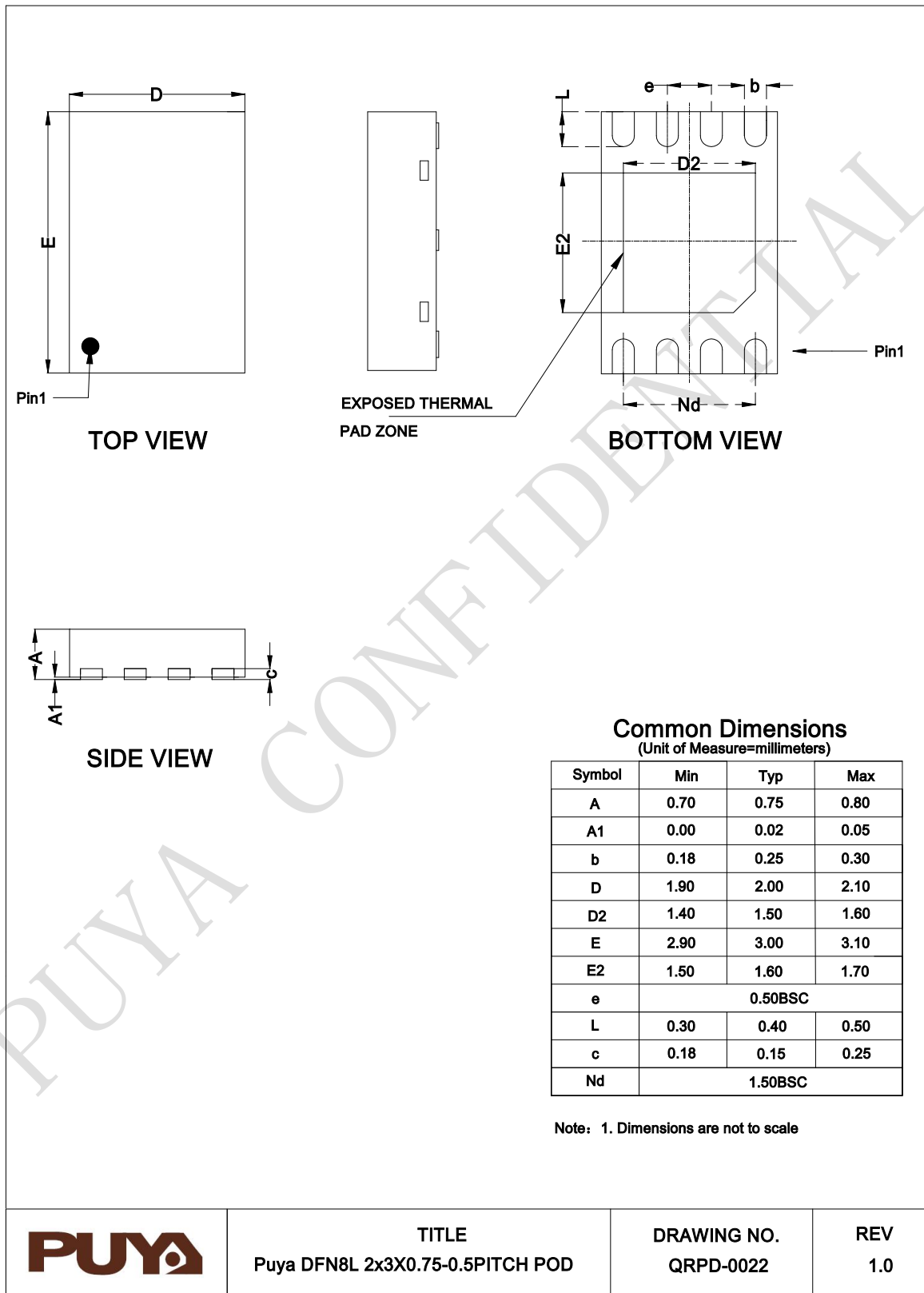

7.5 UDFN8

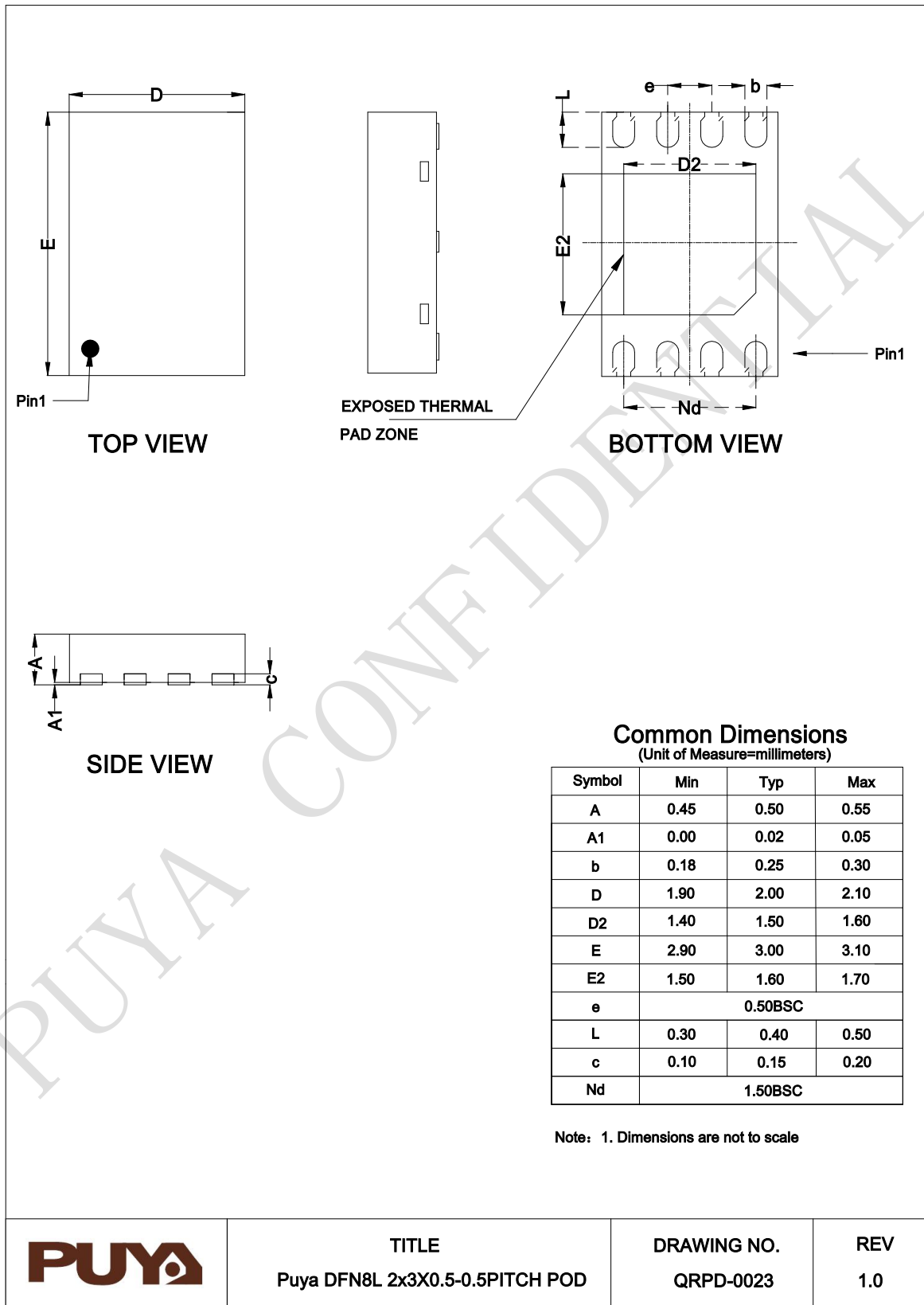

7.6 MSOP8

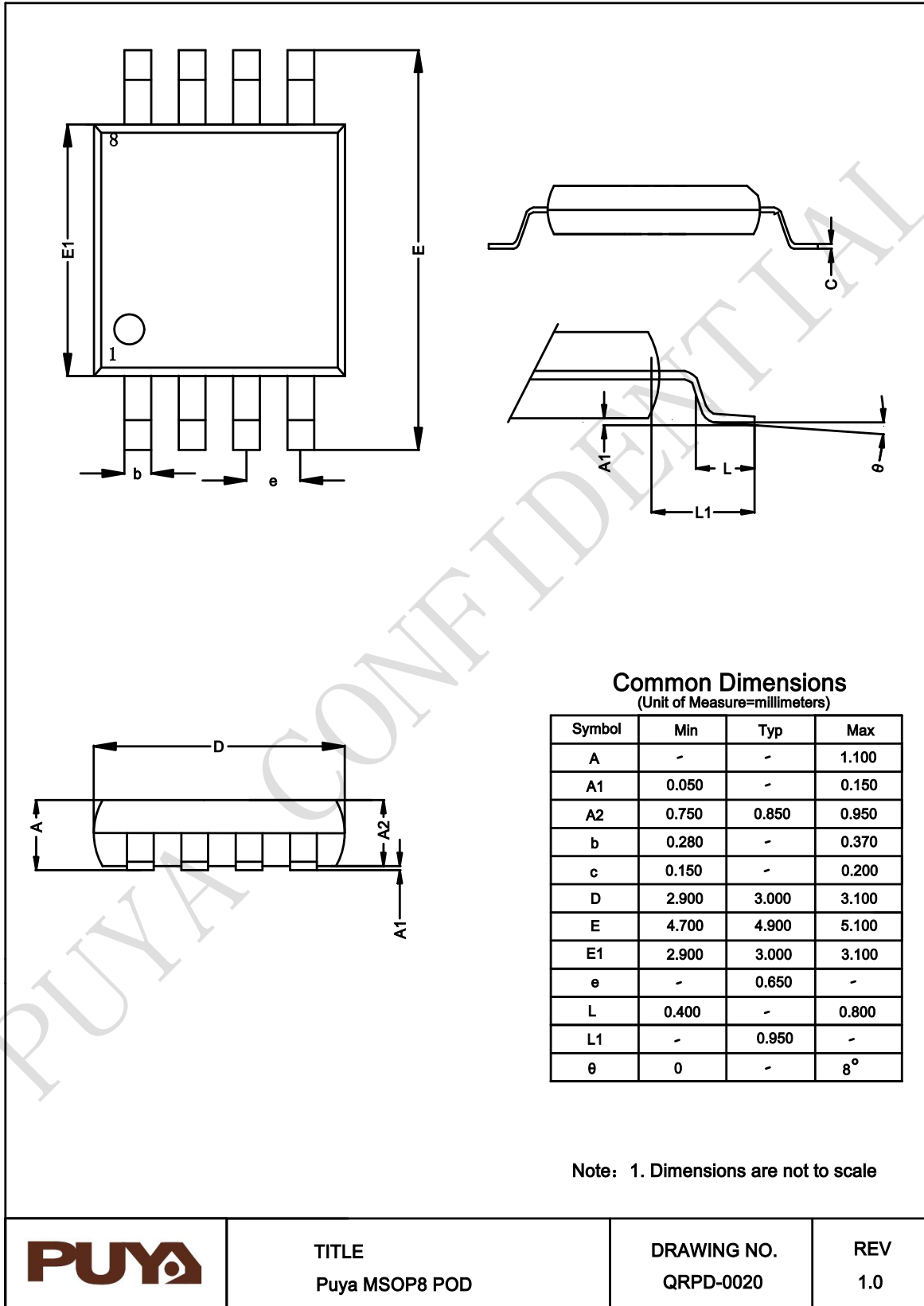

Common Dimensions
(Unit of Measure=millimeters)

Symbol	Min	Typ	Max
A	-	-	1.100
A1	0.050	-	0.150
A2	0.750	0.850	0.950
b	0.280	-	0.370
c	0.150	-	0.200
D	2.900	3.000	3.100
E	4.700	4.900	5.100
E1	2.900	3.000	3.100
e	-	0.650	-
L	0.400	-	0.800
L1	-	0.950	-
θ	0	-	8°

Note: 1. Dimensions are not to scale



TITLE
Puya MSOP8 POD

DRAWING NO.
QRPD-0020

REV
1.0

8. Revision History

Version	Content	Date
V1.0	Initial Release	2020-01-17
V1.1	Add Device Power up/ Power down description	2022-04-15
V1.2	(1) Update t_{DH} of 'Fast Mode AC Characteristics' and Package information (2) Update $t_{SU.WCB}$ and $t_{HD.WCB}$ of 'AC Characteristics'	2022-06-03
V1.3	Update 'Power Up Sequence'	2023-01-14
V1.4	(1) Update feature description (2) Update t_F of 'Fast Mode AC Characteristics' (3) Update Serial Number description (4) Update PDIP8 POD (5) Update TSSOP8 POD (6) Update SOP8(150mil) POD	2025-05-15



Puya Semiconductor Co., Ltd.

IMPORTANT NOTICE

Puya Semiconductor reserves the right to make changes without further notice to any products or specifications herein. Puya Semiconductor does not assume any responsibility for use of any its products for any particular purpose, nor does Puya Semiconductor assume any liability arising out of the application or use of any its products or circuits. Puya Semiconductor does not convey any license under its patent rights or other rights nor the rights of others.